

Hi-MO X6 Explorer (V2)

LR5-72HTH 565~585M

- Suitable for Distribution Market
- Simple design embodies modern style
- Better energy generation performance
- High-quality module guarantees long-term reliability



15-year Warranty for
Materials and Processing



25-year Warranty for Extra
Linear Power Output

Complete System and Product Certifications

IEC 61215, IEC 61730, UL 61730

ISO9001:2015: ISO Quality Management System

ISO14001: 2015: ISO Environment Management System

ISO45001: 2018: Occupational Health and Safety

IEC62941: Guideline for module design qualification and type approval

LONGI



22.6%
MAX MODULE
EFFICIENCY

0~3%
POWER
TOLERANCE

<1.5%
FIRST YEAR
POWER DEGRADATION

0.40%
YEAR 2-25
POWER DEGRADATION

Additional Value

25-Year Power Warranty

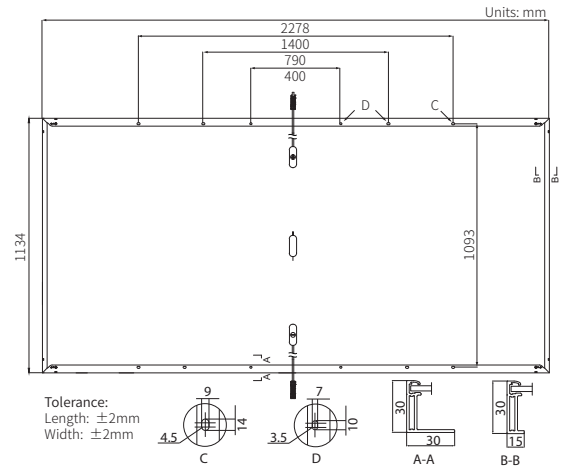
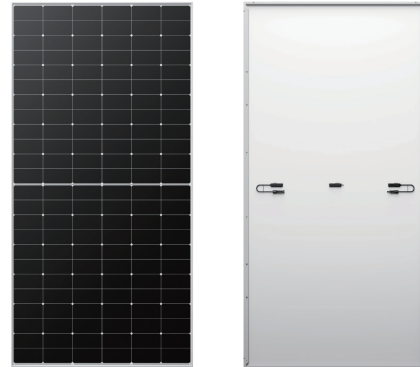
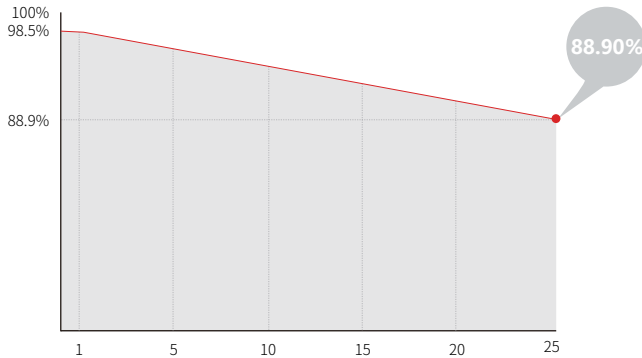

Mechanical Parameters

Cell Orientation	144 (6×24)
Junction Box	IP68
Output Cable	4mm ² , +400, -200mm/±1400mm length can be customized
Glass	Single glass, 3.2mm coated tempered glass
Frame	Anodized aluminum alloy frame
Weight	27.2kg
Dimension	2278×1134×30mm
Packaging	36pcs per pallet / 180pcs per 20' GP / 720pcs per 40' HC

Electrical Characteristics

STC: AM1.5 1000W/m² 25°C

NOCT: AM1.5 800W/m² 20°C 1m/s

Test uncertainty for Pmax: ±3%

Module Type	LR5-72HTH-565M		LR5-72HTH-570M		LR5-72HTH-575M		LR5-72HTH-580M		LR5-72HTH-585M	
	STC	NOCT	STC	NOCT	STC	NOCT	STC	NOCT	STC	NOCT
Maximum Power (Pmax/W)	565	422	570	426	575	430	580	433	585	437
Open Circuit Voltage (Voc/V)	51.76	48.60	51.91	48.74	52.06	48.88	52.21	49.02	52.36	49.16
Short Circuit Current (Isc/A)	14.01	11.31	14.07	11.36	14.14	11.42	14.20	11.47	14.27	11.52
Voltage at Maximum Power (Vmp/V)	43.61	39.79	43.76	39.93	43.91	40.07	44.06	40.20	44.21	40.34
Current at Maximum Power (Imp/A)	12.96	10.61	13.03	10.68	13.10	10.73	13.17	10.78	13.24	10.84
Module Efficiency(%)	21.9		22.1		22.3		22.5		22.6	

Operating Parameters

Operational Temperature	-40°C ~ +85°C
Power Output Tolerance	0 ~ 3%
Voc and Isc Tolerance	±3%
Maximum System Voltage	DC1500V (IEC/UL)
Maximum Series Fuse Rating	25A
Nominal Operating Cell Temperature	45±2°C
Protection Class	Class II
Fire Rating	UL type 1 or 2 IEC Class C

Mechanical Loading

Front Side Maximum Static Loading	5400Pa
Rear Side Maximum Static Loading	2400Pa
Hailstone Test	25mm Hailstone at the speed of 23m/s

Temperature Ratings (STC)

Temperature Coefficient of Isc	+0.050%/°C
Temperature Coefficient of Voc	-0.230%/°C
Temperature Coefficient of Pmax	-0.290%/°C